

Improvement of Power Quality Using Static VAR Compensator

Prof. Manoj R.Wankhade¹, Prof. Shilpa M. Patil², Prof. Komal P. Hole³

^{1,2,3}Assistant Professor, Department of Electrical Engineering, Padm. Dr. V.B.K.C.O.E. Malkapur, Maharashtra, India

ABSTRACT

The electric traction in the transportation sector has become a mainstay due to its low pollution, superior performance, lower maintenance cost and lower energy cost. The fluctuation of voltages is one of the main problem in the railway supply grids due to the variation in load. In this paper one of the FACTS device i.e. SVC (Static Var Compensator) is proposed as a voltage regulator in the traction system and for the better result used closed-loop SVC. The basic idea of the voltage control, using a SVC is to inject or absorb the reactive power by using TCR and TSC according to the variable load condition. This method of compensation can be regulate voltage, filter and raise the utilization rate of the power supplying equipment capacity, and get better power factor.

Keywords:-Closed-Loop Traction System, Static Var Compensator (SVC), FACTS devices, Voltage regulation, Fault Analysis, Harmonic reduction.

1.INTRODUCTION

To serve as one of the main transportations and carriers of the world nowadays, electrified railway is developing rapidly in its speed and length of line. They are growing at great speed throughout the world. The increase in traffic on presented tracks combined with new high speed rail projects mean rail traction is fast becoming an essential load on electric supply grids. The generating station supplied power to the grid substation via three phase distribution system. The three phase distribution system has a voltage level of 220 kv from normal. But the Indian railway acknowledged the 25 kv system therefore the available three phase voltage has to be step down to 25 kv. The step down transformer is connected to any of two phases of normal three phase lines to step down the 220 kv to 25 kv. This causes imbalance and dip in voltage in three phase system. For balancing of the load on the traction power system, the OHE contact wires are supplied from A-B, B-C, and C-A at regular intervals (about 40-60Km) at traction substation. If one phase is fed from A-B then the next substation is fed from B-C phase. This type of combination of phases does not change the phase sequence of the system. To avoid the short circuit between the phase's neutral section or dead zone is provided between two consecutive sections which is powered from two different set of phases.

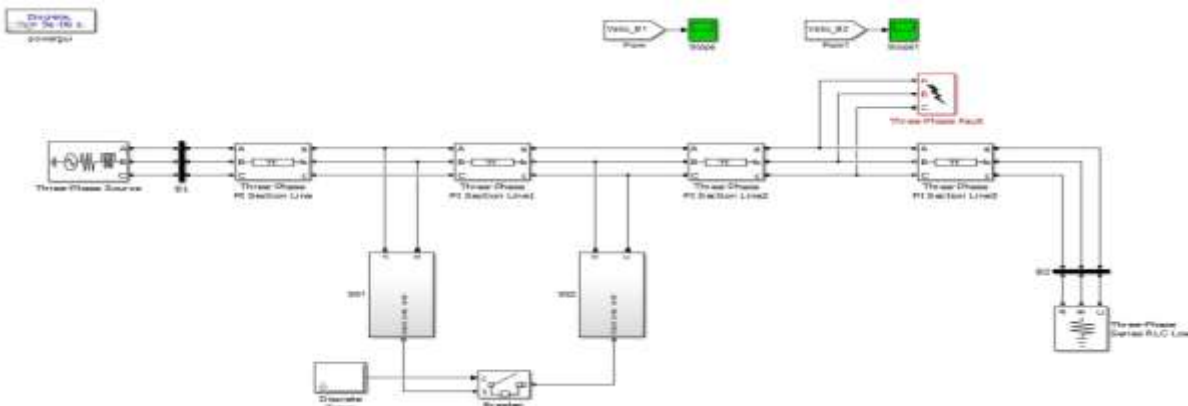

Fig.1 Feeding arrangement of power to traction system

Fig.1 shows, two substations are fed from different phases and in between this bridge interrupter is shown. The bridge interrupter is for loco to switch over safely from A-B phase to B-C phase. In the these system creates complicated situation by keeping same switching time of both substation and fault at a time i.e [0 0.3]so that generates maximum harmonic distortion and voltage becomes decreases. To mitigate all these problems Closed-loop Static Var Compensator (SVC) have used for the better and smooth result.

2. STATIC VAR COMPENSATOR (SVC)

The SVC is one of the advanced power electronic equipments which provides fast and continuous reactive power supply to the system. The application of advanced control technology, closed-loop SVC is used for the improved utilization of the traction system. The SVC is a shunt connected FACTS device which gives the fast control by absorbing or injecting reactive power to maintain the voltage level. It is most essential to balance supply and the demand of active and reactive power in electrical power system. SVC consist of Thyristor Controlled Reactor (TCR), Thyristor Switched Capacitor (TSC)

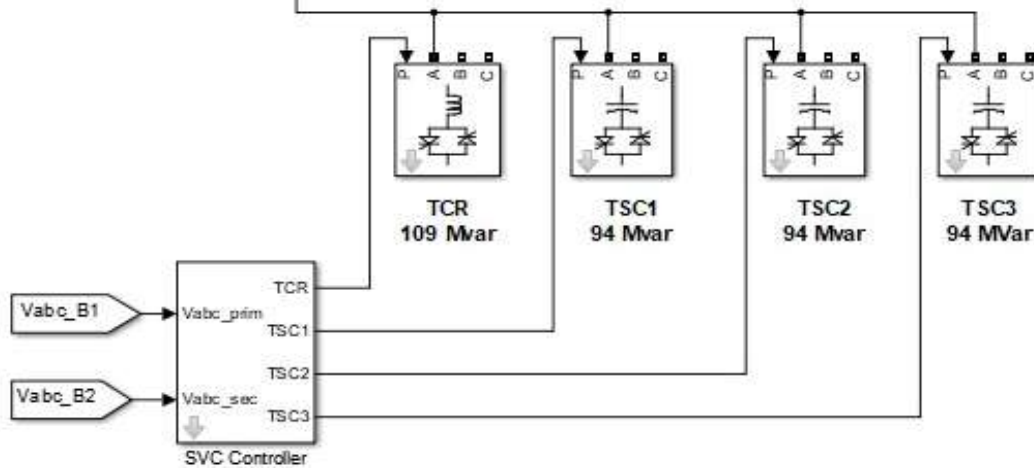

Fig.2 Closed-Loop SVC Model

The SVC technology is allowed for the improved traction system with minimal infrastructure investment, environmental impact and the implementation time compared to the new transmission system. These FACTS technologies provide the better solution as cost-effective alternatives to the new transmission line construction. The best benefits of SVC equipment are now widely recognized by the power systems engineering.

3. TRACTION SUBSTATION

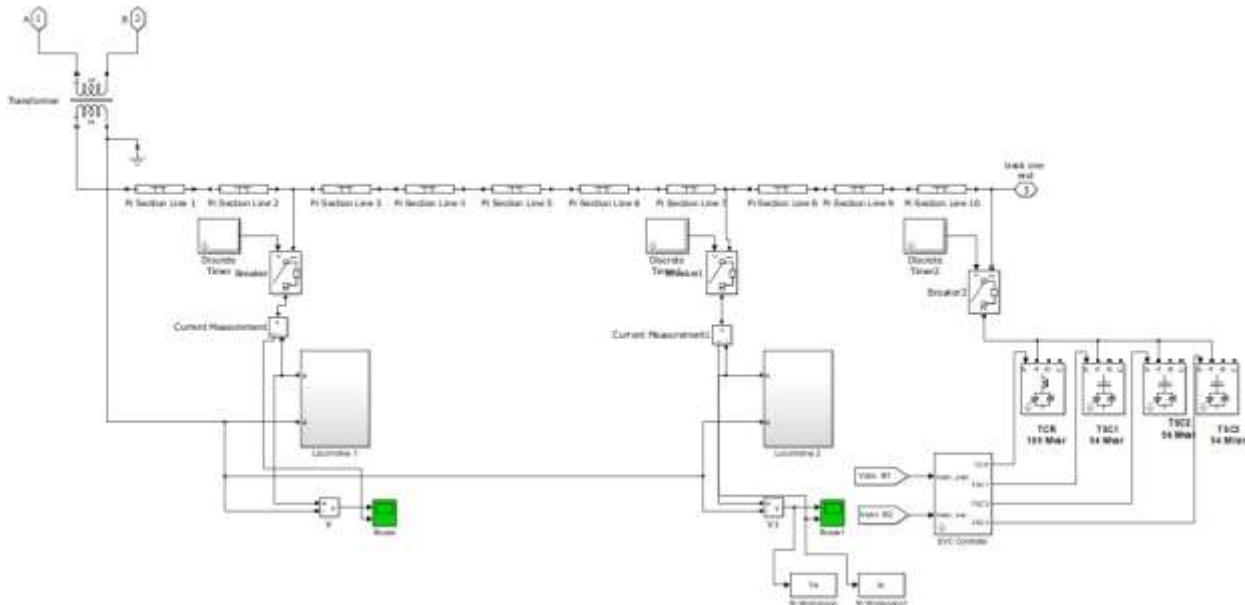

Fig.3 Feeding Arrangement of locomotive with Closed-Loop SVC

At traction substation 220 kV is step down to 25 kV through single phase transformer. The 25 kV AC voltage is drawn as single phase system from a three phase systems. One connection of transformer is permanently solidly earthed which work as return. In traction substation not only consists of transformer but also various protective devices. The protective devices are lightning, arrestor, circuit breaker, transformer protection etc.

In the feeding arrangement of locomotive used Closed-Loop SVC. The Closed-Loop SVC consist of thyristor control reactor (TCR) and the multiple thyristor switched capacitor (TSC). The TSC provide the faster and more reliable solution to the capacitor switching operation. The applications of TSC's are also available for providing stepwise control of the capacitive reactive power.

4. LOCOMOTIVE SUBSYSTEM

The 25kv Ac voltage required for the propulsion of locomotive is taken from OHE lines via pantograph. Then the voltage is step-down to 400v by using transformer. The AC or DC drives are used for the locomotive. Here For the traction system used DC series motor. First these AC voltage is converted into DC voltage by using rectifier and used dc boost converter for maintaining the constant voltage then fed these constant voltage to the DC series motors.

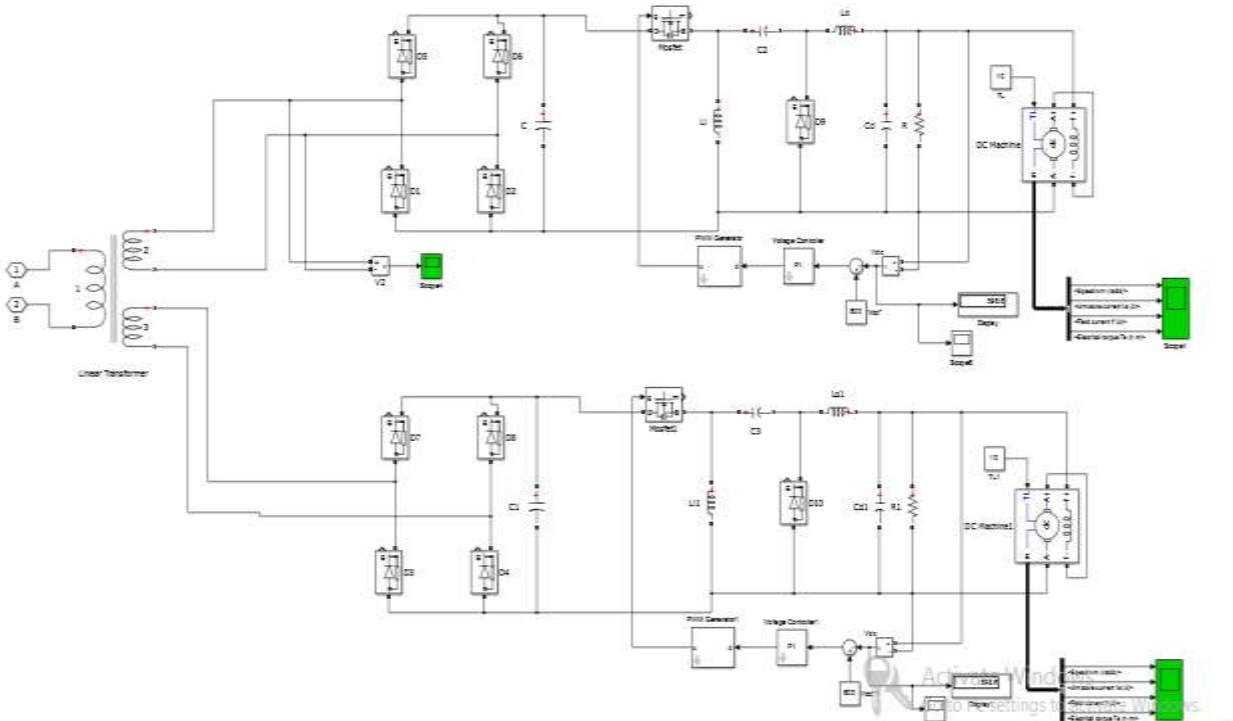

Fig.4 Locomotive design with dc boost converter

These simulated model gives the better performance using closed-loop SVC and the result are clearly shown here.

5. RESULT ANALYSIS

The result of locomotives of substation1(SS1) and substation2(SS2) shows the waveform of voltage and current profile. The switching time of locomotive2 is [0 0.1]. The switching time of fault and SVC is [0 0.3] and [0 0.6] respectively.

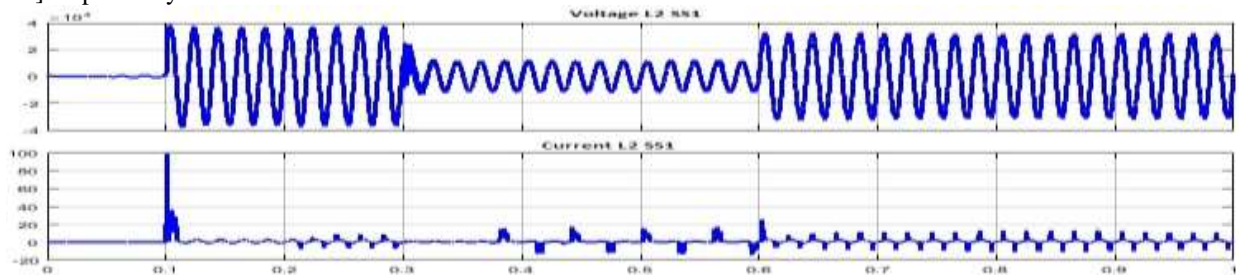

Fig.5 Voltage and Current waveform of Loco2_SS1

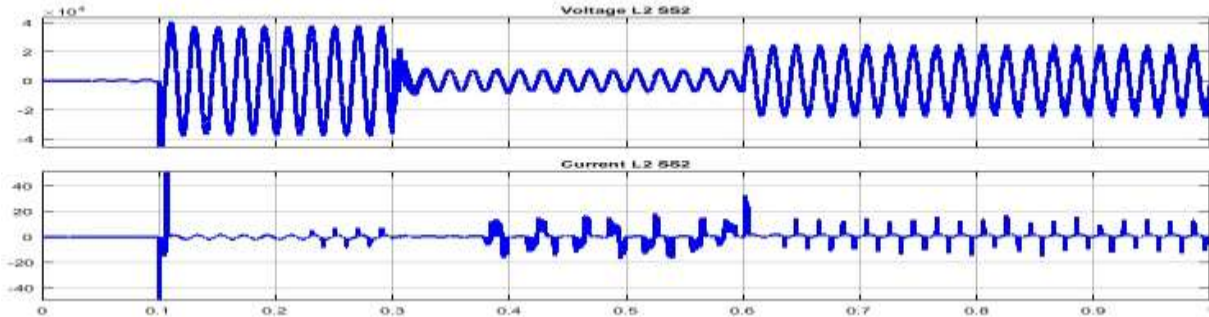

Fig.6 Voltage and Current waveform of Loco2_SS2

Above waveform shows that, when the fault occur at 0.3 then the voltage becomes decreases upto 0.6 but when the SVC inject at 0.6 then the voltage becomes balance for both substation by compensating of reactive power into the system.

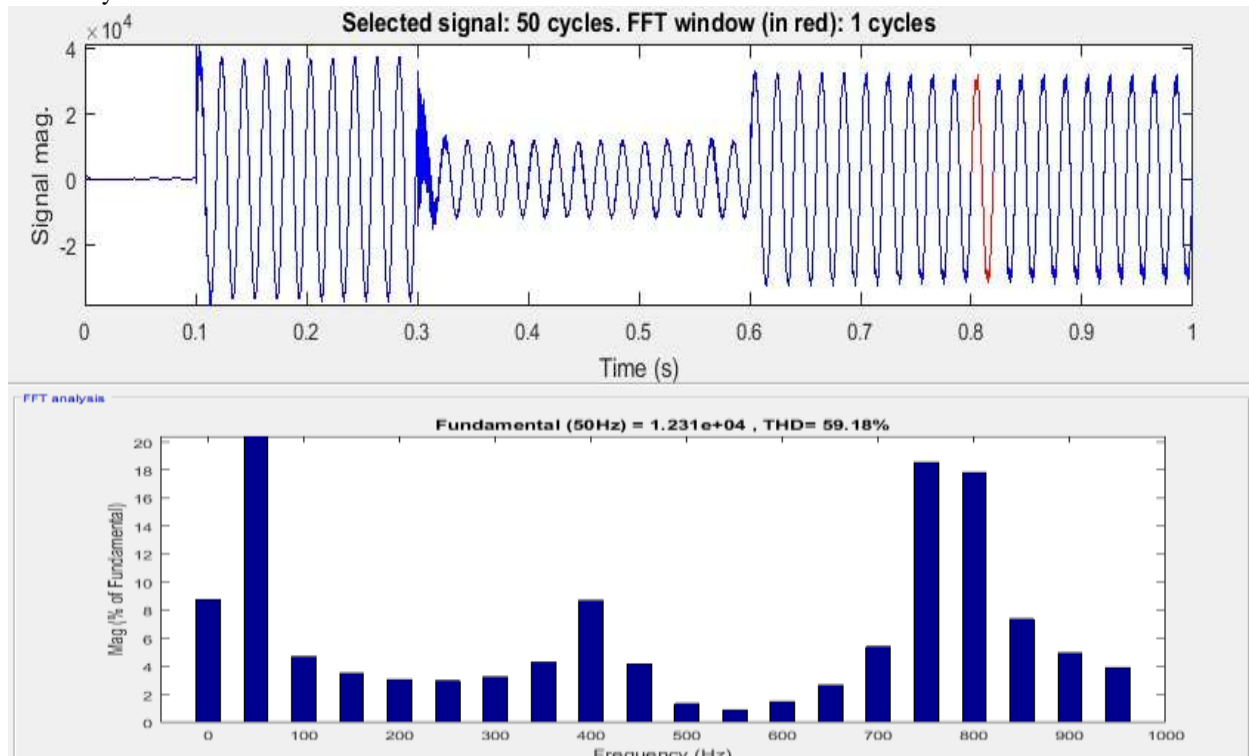

Fig.7 THD of Voltage at 0.3 when fault occur (During Fault)

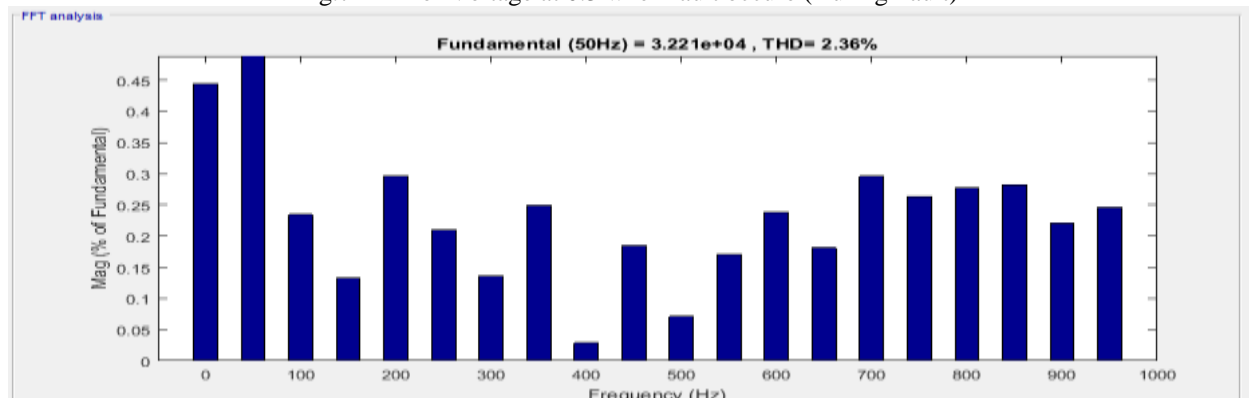

Fig.8 THD of Voltage at 0.6 when inject Closed-Loop SVC (During Fault)

When fault occurs at the switching time of [0 0.3] then the THD of voltages is 59.18%. but when the SVC is injected into the system at switching time [0 0.6] then the THD of voltages is 2.36%.

6. CONCLUSION

From the result it is concluded that the closed-loop SVC gives the better and smooth result in the traction system.

1. When any tripping occurs in the system voltage becomes decrease but when the SVC is injected into the system voltage will increase.
2. The reduction in harmonic distortion during fault in the voltage profile using SVC.
3. The closed-loop SVC improves the voltage profile and gives the better result.

7. REFERENCES

- [1] Lalit G. Patil, "Facts in voltage profile improvement of open-loop traction system", Vol.2, Issue 1 in 2016.
- [2] Shweta E. Kale, K. D. Joshi, "Railway traction system:Current status and opportunities", Vol.10 in 2017.
- [3] de Almeida, L. Moreira. J. Delgada, "Power quality problems and new solutions", Vol. 1 in April 2003.
- [4] B. R. Lakshmikantha, Dr. Murugesh Mudaliar, Dr. K. Bularaman, Dr. R. Nagaraja, "Mitigation of voltage unbalance in traction system", in Oct. 2008
- [5] John Jacob and E. K. Bindumol, "Power quality improvement in railway traction using railway power quality conditioner", in 2013
- [6] Shubra (MIEEE, LMIETE), "MATLAB/Simulink based model for 25KV AC electric traction drive", Vol.3 Issue 5, in May 2014.
- [7] Rekha T. , Dr. Bisharathu Beevi A., "Power quality control in DC traction systems using SVC and harmonic filter", Vol. 3, Issue 10, in Oct. 2014.
- [8] Rajeev B. R, G. N. Madhu, "Voltage enhancement assessment using SVC Facts controller", Vol 2, Issue 10, in Oct. 2014.
- [9] Rajshree S Thorat, M. M. Deshpande, "Power quality issues in railway electrification", Vol. 4, Issue 01, in Jan. 2016.
- [10] Haidar samet, Ebrahim farjah, "Optimizing the location and size of SVC to compensate the railways voltage drop and a novel approach for controlling SVC", in Journal of Electrical Engineering.
- [11] Dr. S. Siva Prasad, A. Praveen Kumar, S. Suresh, "An Innovative compensation negative sequence for power quality issues in traction system", in March 2017.
- [12] N. P. Ghushhe, U. A. Jawadkar, "Enhancement of power system stability using static VAR compensator (SVC)", Vol. 5, Issue 08, in Aug. 2017
- [13] J. Shree Mathi, and S. Neelan, "Hybrid Power quality conditioner for railway application using RLC pair circuit", Vol. 1, Issue 03, in April 2017.
- [14] Mithilesh Singh, Shubrata Gupta, "Power quality improvement in power system with FACTS devices", Vol. 6, Issue 02, in Sept. 2017.
- [15] G. Celli, F. Pilo, S. B. Tennakoon, "Voltage regulation on 25 KV AC railway systems by using Thyristor Switched Capacitor", of IEEE.
- [16] Pelin Fidan, Huseyin Akdemir, Bedri Kekezoglu, Ismail Adiyil [17], "Quality problems in railway transportation systems", Vol. 03, Issue 07, in July 2018.
- [17] M Asrar Ur Rahman and M Sabah ul Islam, " Voltage control and dynamic performance of power transmission using static Var compensator", Vol. 1 in 2014.
- [18] Sandesh Jain, Shivendra Singh Thakur, "Voltage control of transmission system using static VAR compensator", Vol. 1, Issue 2 in 2012.
- [19] Matilda Ornkloo, "Compensating unbalances in synchronous railway traction systems with railway power conditioners", in Jan. 2016.
- [20] A. Nabisha, S. Marshelinco, Dr. X. Felix Joseph, " Power Quality Enhancement Using FACTS Devices - Literature Review", Vol.02, Issue12, in 2016.