

The Stimulation and Analysis of Grid Tied Inverter for Renewable Energy Sources

Malti Ashok Dorsatwar¹ Prof. Y. P. Sushir²

¹ Student, Department of ENTIC Engineering, Padm. V.B. Kolte College of Engineering, Malkapur, Maharashtra, India

² Assistant Professor, Department of ENTIC Engineering, Padm. V.B. Kolte College of Engineering, Malkapur, Maharashtra, India

ABSTRACT

The renewable energy sources for manufacturing the electrical energy tend to be increasing day by day to satisfy the increasing energy demand. Electrical energy supported by the renewable energy source is most popular to store in electrical batteries and can transfer to the electrical grid directly because of usability and efficiency. Therefore, a grid-tied inverter that transfers current to the grid. For this method, the inverter mechanism is thus necessary. On the other hand, the inverter output voltage should be synchronized with grid voltages; therefore, the phase angle and amplitude of the grid voltages should be obtained accurately and quickly. To achieve the appropriate grid synchronization, Phase-Locked Loop (PLL) algorithms are widely used. During this paper, a three-phase space vector pulse width modulation (SVPWM) controlled grid-tied inverter is simulated in MATLAB/Simulink and analyzed. All simulation and experimental results ensure that the output voltages of the grid-tied voltage source inverter are compatible with the grid and grid synchronization is successfully achieved because of the PLL algorithm. Phase, frequency, and amplitude of phase voltages are foremost necessary and basic parameters that ought to be controlled in a grid-connected application. The aim of this paper is to present a review of assorted synchronization techniques for pulse width modulated voltage source inverter.

Keywords – grid synchronization, inverter, PLL, SVPWM, Renewable energy sources.

1. INTRODUCTION

1.1 Background

In the recent years, the studies on renewable energy sources (RES) have accrued quickly as a result of fossil-based energy sources have decreased and these sources have seriously broken to the health of all living creatures, and to the atmosphere. Within the world, electricity production from the RES tends to rise daily so as to fulfill the increasing energy demand, and to enable energy to be obtained additionally economically and cleanly [1]. Electrical energy created from the RES is most well-liked to transfer to the electrical grid rather than storing in batteries. But, the created energy isn't transmitted to the grid directly due to usability and efficiency. Several conditions should be provided to transmit the energy to the grid. These conditions are sinusoidal-shaped waveform, continuity of voltage, fixed-frequency, being balanced of the produced voltages, to be among specific limits of current harmonics. During this regard, three-phase inverter is used at high powers to transfer voltage to the grid. So, management of the inverter, called as grid-tied inverter, is extremely necessary [1].

1.2 Different power quality issues of the Renewable Energy System

In case of renewable energy systems, two major types of power quality problems exist. Those are voltage and frequency fluctuations and harmonics. Voltage and frequency fluctuations are mainly caused by two reasons: i) non-controllable variability of renewable energy resources, and ii) power grid-side disturbances. Harmonics are made by power electronic converters that are used in renewable energy generation. As outlined by the IEEE normal 929-2000, there are four major parameters to judge the facility quality in PV systems like voltage, voltage flicker, frequency, and distortion. Deviation from these parameters creates power quality issues. The inverter is also needed to stop power quality deviation within the utility lines during this case [8]. Those issues are often mentioned from two angles: renewable energy side, and power grid side. At first, we have a tendency to discuss about the renewable energy side. Wind and solar PV power generation each experience intermittence because of a mixture of partial unpredictability options of wind and solar resources and non-controllable variability - that cause fluctuations within the performance of each wind and PV power generation. Outputs of those two varieties of

renewable energy sources vary greatly because of the variations in wind speed and incident solar energy. Major problems are voltage and frequency fluctuations.

1.3 Effect of poor synchronization on grid system

When driving power to the grid, grid tied inverters should offer a stable, sinusoidal AC waveform that matches grid voltage and frequency in line with utility standards.

Following are the results of poor grid synchronization on grid system

1. Poor synchronization causes the load imbalance
2. Poor synchronization causes injury to the connected equipment
3. Poor synchronization causes instability within the grid
4. Poor synchronization causes power outages within the grid itself.

2 ELECTRICAL STANDARDS FOR SYNCHRONIZATION

2.1 IEEE 1547

The Institute of Electrical and Electronics Engineers (IEEE) Standard 1547 has been a foundational document for the interconnection of distributed energy resources (DER) with the electric power system or the grid. 1547 is exclusive because the only American National Standard addressing systems-level DER interconnected with the distribution grid. It's had a major impact on however the energy industry will business and it ought to still influence the method electric power systems operate so much into the future. IEEE 1547 has helped to modernize our electric power systems infrastructure by providing a foundation for group action clean renewable energy technologies in addition as alternative distributed generation and energy storage technologies. IEEE 1547 provides obligatory purposeful technical needs and specifications, in addition as flexibility and decisions, concerning instrumentation and in operation details that are in compliance with the quality.

2.2 IEC61727

As an global standard, IEC 61727 specifies the most needs of a grid interface which is able to make sure that it's each purposeful and safe for PV connections of 10 kVA or less. Most the desired functionality to befit the quality is enforced among the PV systems inverter. Once the utility limits move outside traditional operational bounds the inverter ought to disconnect itself from the grid. Inverter Output Power Quality - the output of any inverter ought to operate among the following limits: The inverter should limit the injection of any D.C. current into the utility but less than 1% of its rated output.

3. METHODOLOGY

3.1 Introduction

MATLAB might be a superior language for technical computing. It integrates the computation, visualization, associated programming in an easy-to-use setting wherever issues and solutions area unit expressed in familiar mathematical system. Typical uses include: science and computation Algorithm program development modelling, simulation, and prototyping knowledge analysis, exploration, and visualization Scientific and engineering graphics application development, also as graphical computer program building. MATLAB is associate interactive system whose basic knowledge component is associate array that doesn't need orienting. This permits us to unravel several technical computing issues, particularly those with matrix and vector formulations, in a very fraction of the time it'd desire write a program in a scalar non interactive language like C or algorithmic language. The name MATLAB stands for matrix laboratory. MATLAB was originally written to supply quick access to matrix software system developed by the LINPACK and EISPACK comes, that along represent the progressive in software system for matrix computation. MATLAB has evolved over a amount of years with input from several users. In university environments, it's the quality tutorial tool for introductory and advanced courses in arithmetic, engineering and science. In business, MATLAB is that the tool of selection for high-productivity analysis, development and analysis. MATLAB options a family of application-specific solutions referred to as toolboxes. Vital to most users of MATLAB, toolboxes enable you to be told and apply specialized technology. Toolboxes are unit comprehensive collections of MATLAB functions (M-files) that reach the MATLAB setting to unravel explicit categories of issues. Areas during which toolboxes are unit out there embrace signal process, management systems, neural networks, mathematical logic, wavelets, simulation, and lot of others.

3.2 Control technique use for inverter in project

There are unit many PWM techniques accessible for giving switch pulses to VSI. Among alternative techniques, the Sinusoidal Pulse Width Modulation (SPWM) is employed during this style since it will directly management the inverter output voltage and output frequency per sine functions. The voltage supply inverter ought to be managed in such the way on generate the voltages that area unit same because the reference voltages generated by the detection and control block. The voltage supply inverter uses the PWM switch techniques to process a DC input voltage ($V_{dc}=V_s$) that's typically constant in magnitude. The inverter job is to require this DC input and to allow AC output, wherever the magnitude and frequency are often controlled. The potency parameters of associate inverter like the switch losses and therefore the harmonic reduction area unit in the main obsessed on the modulation method wont to management the inverter. Sinusoidal pulse width modulation (SPWM) is wide utilized in power physics to modify the power so a sequence of voltage pulses are often generated by the on and off of the power switches. The PWM inverter has been the most selection in power physics for many years, as a result of its circuit simplicity and rugged management theme. The SPWM switching technique is usually utilized in industrial applications.

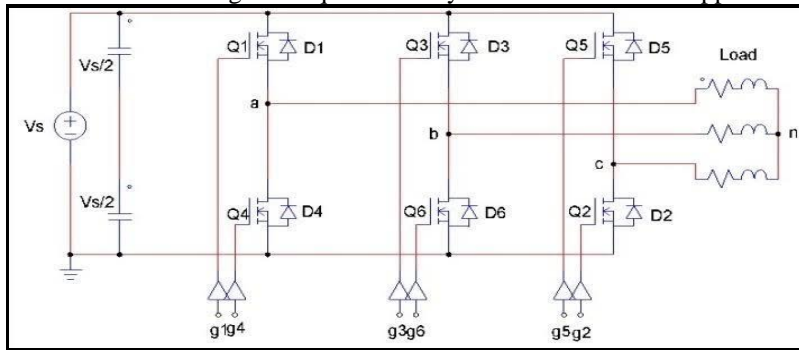

FIGURE: - 2.1 Three-phase voltage sourced inverter

3.3 Mathematical Analysis

Figure 6.3 shows the control structure of PLL. Different techniques can be used to implement each blocks of PLL. In this case PD is implemented using a multiplier, LF using a LPF and VCO containing PI controller, an integrator and a sinusoidal function.

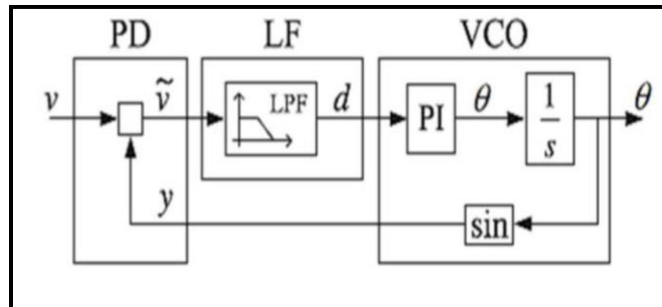

Figure 2.3 Control Structure of PLL

For input signal $V = V_m \cos \theta_g$, with $\theta_g = \omega_g t + \phi_g$ and output signal $y = \sin \theta$, with $\theta = \omega t + \phi$, the output of PD is:

$$\tilde{v} = v y = V_m \sin \theta_c \text{ -----(I)}$$

$$\tilde{v} = \frac{V_m}{2} \sin (\theta - \theta_g) + \frac{V_m}{2} \sin (\theta + \theta_g) \text{ -----(II)}$$

$$\tilde{v} = \frac{V_m}{2} \sin [(\omega - \omega_g)t + (\phi - \phi_g)] + \frac{V_m}{2} \sin [(\omega + \omega_g)t + (\phi + \phi_g)] \text{ ----- (III)}$$

The first term of eq(III) is a low frequency component which contains the phase difference between v and y and the second term is high frequency component which is filtered out by the loop filter. Hence, the output of LF is

$$d = \frac{V_m}{2} \sin [(\omega - \omega_g)t + (\phi - \phi_g)] \text{ -----(IV)}$$

Which is fed to PI controller to generate estimated frequency $\omega = \theta$ until $d = 0$. The estimated frequency is then integrator to form the phase of output signal $y = \sin \theta$, which is sent back to PD to complete the loop. In steady state, when d is driven to zero and $\omega = \omega_g$ with $\phi = \phi_g$, the phase of output signal is said to be locked with that of input signal y. Hence, phase of input signal and output signal is contemporized.

4. CONCLUSION & FUTURE SCOPE

4.1 Conclusion

This methodology represents a simulated model of three phase grid tied inverter and closed loop current management theme for identical. The simulation of system is simulated in MATLAB through PLL based mostly PWM technique by using DC supply. The planned system is capable for synchronizing with grid with very little distortion as per grid demand. It is simply discovered from the waveforms that there's scope for additional analysis in rising the standard of the power. After the compensation, the grid voltage and current are in phase with inverter voltage and current. The SPWM technique is very useful in rising the power quality. The THD is well below the limit 5%. The performance of the shunt active power filter is analysed using the SPWM technique for minimizing the harmonics, compensating the reactive power and rising the power factor in the power system. This system is used to manage the VSC of custom power devices. The planned change technique uses a sinusoidal reference signal and an inverted sine wave as the carrier signal. The SPWM technique generates lower voltage THD and low change losses in comparison with the traditional PWM technique.

All simulation results and analysis confirmed that the output voltages of the SPWM controlled grid tied inverter are balanced with the grid and grid synchronization is with success achieved. The low dynamic designed dq-PLL and adaptive PLL prove to overcome all the test conditions. These create them appropriate for grid connected applications, like wind turbines, PV or fuel cell systems

4.2 Future Scope

1. Grid operating may be a nice want of style the system which will manage the look of inverter power.
2. It makes the system sensible by coordinate with the IT system.
3. It's useful for nature and human.
4. The natural sources are to be helpful for creating these systems.
5. Additional analysis in rising the standard of the power.
6. It additionally reduces the pollution and running value of metering.

5. REFERENCES

- [1]. Fehmi Sevilmis and Hulusi Karaca, "An Experimental Study of Grid Tied Inverter for Renewable Energy Systems" Dept. of Electrical and Electronics Engineering Selçuk University Konya, Turkey IEEE pp. 5386-5326 May 2018.
- [2]. Prasad Magdum and Suraj Yadav, "Simulation of Three-Phase Grid Tied Inverter" 2017 2nd International Conference for Convergence in Technology (I2CT) IEEE pp. 5090 Jan 2017.
- [3]. Toomas Vinnal, Marek Jarkovoi and Lauri Kütt, "Harmonic Currents and Voltages in LV Networks of Estonia" 2018 IEEE 59th International Scientific Conference on Power and Electrical Engineering of Riga Technical University (RTU CON) European Union July 2018.
- [4]. Neha G.L and Dr. Basavaraja Banakara, "Power Quality Enhancement in Smart Grid by Synchronizing SPWM Inverter and LC Filter" 2nd IEEE International Conference on Recent Trends in Electronics Information & Communication Technology (RTEICT), May 19-20, 2017, India.
- [5]. Mr. Shantanu Chatterjee and Dr. Saibal Chatterjee, "Simulation of Synchronous Reference Frame PLL based Grid Connected Inverter for Photovoltaic Application" Dept of Electrical Engineering NERIST, Arunachal Pradesh Nirjuli, Papum Pare, India IEEE pp. 4799 Aug. 2015.
- [6]. Saurav Das and Khosru M Salim, "Design and Implementation of One kilowatt Capacity Single Phase Grid Tie Photovoltaic Inverter" International Conference on Electrical Engineering and Information & Communication Technology (ICEEICT) IEEE pp.4799-4819-Feb 2014.
- [7]. Qing-Chang Zhong and Tomas Hornik, "Control of Power Inverters in Renewable Energy and Smart Grid Integration", First Edition, John Wiley & Sons, Ltd. Published 2013.
- [8]. Li Liu, RuiLiu, Qihua Cao, and Qihong Chen, "Design of a three-phase grid tied inverter School of Automation, Wuhan University of Technology, Wuhan 430070, China. IEEE publication pp. 4673-4714 Aug 2016.
- [9]. K.M.S.Y Konara, M.L. Kolhe and W.G.C.A. Sankalpa, "Grid Synchronization of DC Energy Storage Using Voltage Source Inverter with ZCD and PLL Techniques" IEEE publication pp.4799-4876 Aug 2015.
- [10]. A. Kavitha, Dr. N. Senthil Kumar and N.Vanaja, "Design and Control of Grid Synchronization of Renewable Energy Sources" International Conference on Circuit, Power and Computing Technologies [ICCPCT] 2016.