

Unit Vector Template Based DVR for Power Quality Improvement

Sonam R Rathi¹, Y.P.Sushir²

¹ P.G. Student, Electrical Department, Padmashri Dr. V.B. Kolte Collage of Engineering Malkapur, Maharashtra, India

² Assistant Professor, Electrical Department, Padmashri Dr. V.B. Kolte Collage of Engineering Malkapur, Maharashtra, India

ABSTRACT

Power Quality problem mostly refers to Voltage sag, and source current problems and enhance power quality of the system. This paper includes development of voltage control scheme that can compensate voltage sag and swell in three-phase power systems. Faults occurring in power distribution systems cause the voltage sag or swell. If a fault occurs or Heavy inductive loads are switched then the system experiences voltage sag and voltage swell problems. For sensitive loads, even voltage sags of short duration can cause serious problems in the entire system. Normally, a voltage interruption triggers a protection device, which causes shutdown of the entire system. In order to mitigate voltage sag and voltage swell, this research proposes a scheme called "DYNAMIC VOLTAGE RESTORER (DVR)" To enhance the power quality with reference generation and control techniques like Unit Vector Template (UVT). Dynamic Voltage Restorer is a series connected power electronics-based device that can quickly mitigate the voltage sag in the system and restore the load voltage to the pre-fault value. In this paper we go through to relevant power quality problems for a DVR and power electronics controllers for voltage sag and swell mitigation. Thereafter the operation and elements in DVR is described. In this thesis Modelling and simulation of proposed SIMULINK. DVR is implemented in MATLAB

Keyword: - Power Quality, DVR, UVT, MATLAB, Voltage Sag, Voltage Swell

1. INTRODUCTION

The nature of electric power supply is mostly affected by the wide application of power electronic based equipment. Uninterrupted sinusoidal voltage at desired frequency and magnitude should always be provided to the consumers. On the other hand, consumers should draw sinusoidal current. Many researchers are taking effort for the effective improvement of power quality. They are mainly of three categories such as shunt connected distribution static compensator (DSTATCOM), series connected compensator like dynamic voltage restorer (DVR) and unified power quality conditioner (UPQC) which is connected in both shunt and series.[1]

A DVR is connected between the supply and the sensitive load so that it can insert a voltage of required waveform. Hence it can protect sensitive consumer loads from supply disturbances. In a capacitor supported DVR, the power absorbed/supplied is zero in the steady state. The voltage injected by the DVR should be in quadrature with the feeder current [2].

The analysis, design and voltage injection schemes of capacitor supported DVR is discussed in the literature [3]-[5] and the different control strategies are developed [6]-[7]. The instantaneous reactive power theory [6], sliding mode controller based [7], symmetrical components based, control techniques for series compensator are reported in the literature. In this paper, a new control algorithm is developed based on unit templates [8] for the control of capacitor supported DVR for sag, swell, harmonics and unbalance in supply voltage. The computer simulation is performed using MATLAB software with Simulink and power system block set for verifying the proposed control algorithm.

The series APF is connected to the supply line through a series transformer. The series APF prevents the source side voltage disturbances from entering into the load side to make the load voltage at desired magnitude and frequency on the other hand the shunt APF connected in parallel across the load limits the current related problems to the load side to make the current from the source purely sinusoidal.

2. MODELING OF DYNAMIC VOLTAGE RESTORER (DVR)

2.1 Dynamic Voltage Restorer (DVR)

Among the power quality problems like sag, swell, harmonic etc., voltage sag is the most severe disturbances in the distribution system. To overcome these problems the concept of custom power devices is introduced lately. One of those devices is the Dynamic Voltage Restorer (DVR), which is the most efficient and effective modern custom power device used in power distribution networks.

DVR is a recently proposed series connected solid state device that injects voltage into the system in order to regulate the load side voltage. It is generally installed in a distribution system between the supply and the critical load feeder at the point of common coupling (PCC). Other than voltage sags and swells compensation, DVR can also add other features like line voltage harmonics compensation, reduction of transients in voltage and fault current limitations. DVR is a series connected device designed to maintain a constant RMS voltage value across a sensitive load.

2.2 Basic Structure of DVR

The general model of DVR consists of -

- Voltage Source Converter (VSC)
- Injection/ Booster transformer
- Hysteresis Voltage Controller
- DC link
- Harmonic filter
- Energy storage
- Control system

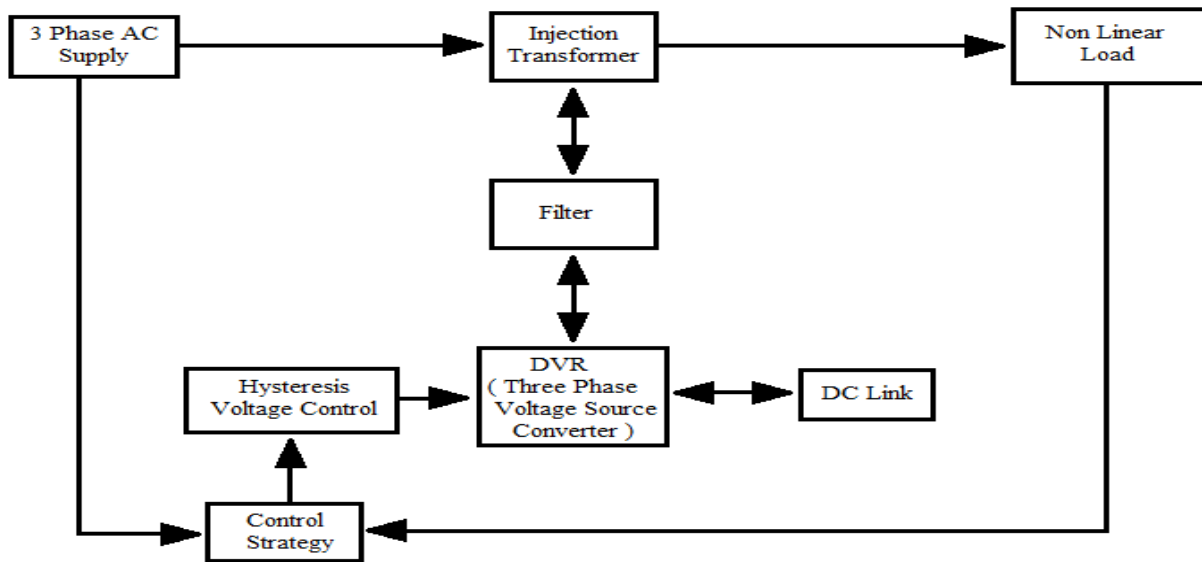

Fig -1 Schematic diagram of DVR

- Voltage Source Converter (VSC):

A VSC is a power electronic converter consists of a DC link storage and Thyristor based switching devices, which can create a sinusoidal voltage. In DVR application, VSC is used to momentarily change the utility voltage or to create the required part of the utility voltage which is missing. There are four main kinds of switching devices- Gate Turn-Off Thyristor- GTO, Metal Oxide Semiconductor Field Effect Transistor- MOSFET, Insulated Gate Bipolar Transistor - IGBT and Integrated Gate Commutated Thyristor- IGCT. The purpose of storage devices is to give the essential energy to the VSC through the dc link for the generation of injected voltages.

- Injection/ Booster Transformer:

The Injection/Booster transformer is a specifically designed transformer that efforts to limit the coupling noise from the primary side to the secondary side. It connects DVR to the distribution side via the High voltage windings and transformers, windings having the ratio of 1:1 and couples the injected compensating voltages created by the voltage source converters to the incoming utility voltage. Injection transformer works for the purpose of isolating the load from the utility disturbances.

The necessary voltage is generated by VSC so that voltage at load side is perfectly balanced and regulated. The series transformer turns ratio should be suitable so that injected voltage is such that it injects a compensating voltage which will completely make the load side voltage balanced.

- Hysteresis Voltage Controller:

Hysteresis-band Pluse width Modulation (PWM) is an instantaneous feedback voltage control technique where the actual voltage continually tracks the command voltage within a hysteresis band.

- DC Link:

The DC link has two main tasks:

- a) The first task is to charge the dc link source during stable operation.
- b) The second task is to keep dc link voltage at the nominal range.

2.3 Control Strategy of DVR Using Unit Vector Template Generation

Unit vector template based, algorithm is used to control the DVR and power quality improvement. Unit vector template (UVT) as proposed in [9] is used as the control technique of the series APF sequence. The distorted supply is used to extract the UVT (Fig-2). In order to achieve this, the DVR insert voltages opposite to the source voltages distortion and/or unbalance present and these voltages cancel each other, resulting in a balanced and required voltage on the load side supply voltages. UVT control strategy is used to obtain the load reference voltage, which is compared with load voltage signals. The error obtained from the above is fed to the hysteresis controller. The hysteresis controller will produce necessary gating signal required for the series inverter as shown in Fig-2.

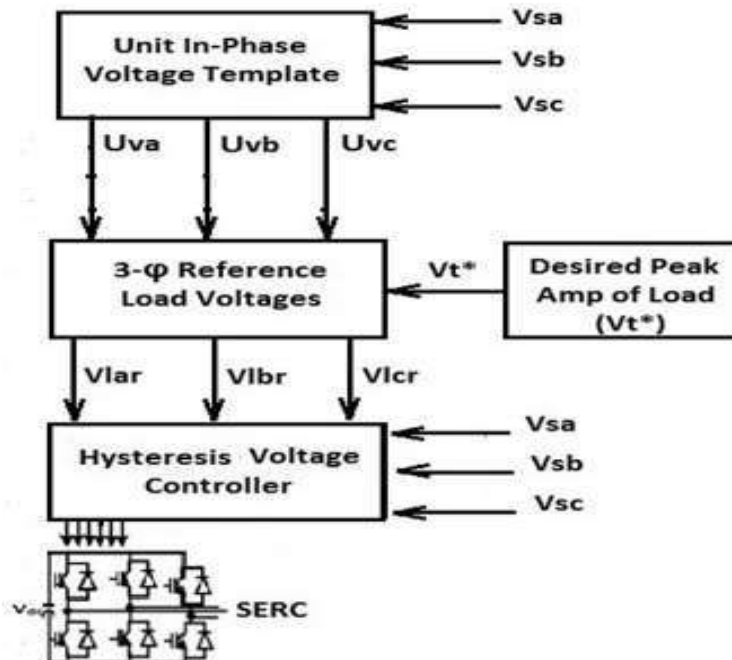

Fig -2 Control Scheme of DVR

The control strategy used for the hysteresis controller is defined in [11] had been used. Pattern of switching the inverters will be specified by the hysteresis band controller. In the extraction of error signal, the hysteresis controller places a vital role. The error signal obtained from the comparison of the load side reference voltage and the instantaneous load side voltage signals.

3. CONVENTIONAL SYSTEM CONFIGURATION OF DVR

The control block diagram of DVR for generating reference voltage signal using Unit vector template Generation (UVTG) (Fig.3). The component of series APF is controlled to appropriate voltage between the point of common coupling (PCC) and load so, that the load voltage becomes balanced, distortion free and maintain desired magnitude.

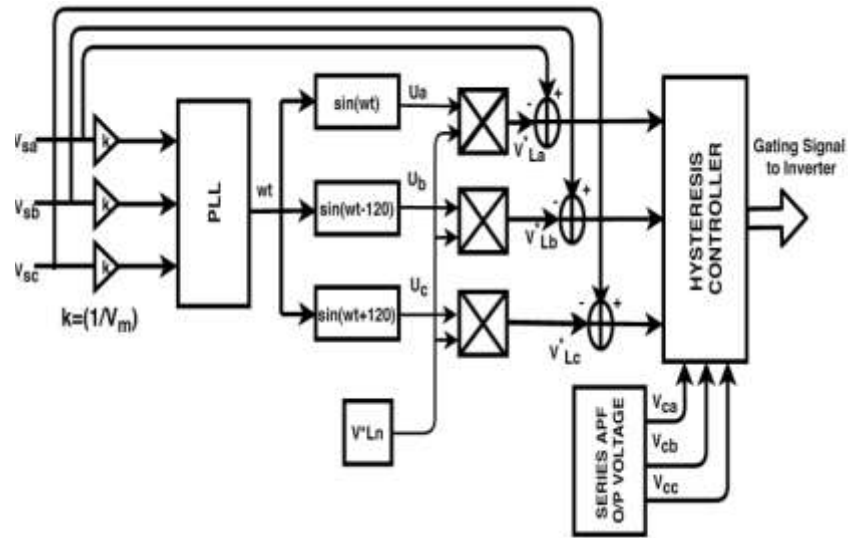

Fig -3 Control Block Diagram of DVR Using UVTG

The three-phase input source voltage may be distorted or any other power quality problems are present at PCC. To get unit vector template signal the input source voltage is sensed and multiplied by gain equal to $1/V_m$. (V_m is equal to peak amplitude of fundamental voltage). The phased locked loop (PLL) is used to achieve synchronization with supply voltage. The extraction of three-phase voltage reference signal for series APF is based on UVTG is achieved by using PLL is given by equation:

$$U_a = \sin(\omega t) \quad (1)$$

$$U_b = \sin(\omega t - 120^\circ) \quad (2)$$

$$U_c = \sin(\omega t + 120^\circ) \quad (3)$$

Now multiplying the peak amplitude of fundamental input voltage with UVTG of equation (1, 2 &3) gives the reference load voltage signal which is given by equation

$$V^*_{Labc} = V_m * U_{abc} \quad (4)$$

For getting distortion free load voltage (V_{Labc}), this load voltage must be equal to reference load voltage (V^*_{Labc}). The sensed load voltage (V_{Labc}) and reference load voltage (V^*_{Labc}) are compared in hysteresis controller to generate switching signals to the switches of series APF

3.1 Unit Template Generator for Series APF:

The series is controlled in such a way that it injects voltages (v_{inj} , v_{injB} and v), which cancel out the distortions present in the supply voltages (v_{sa} , v_{sb} and v_{sc}), thus making the voltages at PCC (v_{la} , v_{lb} and v_{lc}) perfectly sinusoidal with the desired amplitude. In other words, the sum of supply voltage and the injected series filter voltage makes the desired voltage at the load terminals.

Since, the supply voltage is distorted, a phase locked loop (PLL) is used to achieve synchronization with the supply voltage. Three-phase distorted supply voltages are sensed and given to PLL which generates two quadrature unit vectors ($\sin\omega t$, $\cos\omega t$). The in-phase sine and cosine outputs from the PLL are used to compute the supply in phase, 120° displaced three-unit vectors (u_a , u_b u_{lc}) as:

$$V_t = \{2/3(V_{sa}^2 + V_{sb}^2 + V_{sc}^2)\}^{1/2}$$

$$U_{va} = V_{sa} / V_t; U_{vb} = V_{sb} / V_t; U_{vc} = V_{sc} / V_t;$$

Where as V_t is the terminal voltage

$$\begin{bmatrix} u_a \\ u_b \\ u_c \end{bmatrix} = \begin{bmatrix} 1 & 0 \\ -\frac{1}{2} & -\frac{\sqrt{3}}{2} \\ -\frac{1}{2} & \frac{\sqrt{3}}{2} \end{bmatrix} \begin{bmatrix} \sin \theta \\ \cos \theta \end{bmatrix}$$

4. SIMULATION AND RESULTS

In this section the MATLAB simulation and result are presented DVR voltage sag mitigation based on sine template method technique. There are two cases analyzed for the DVR i.e., voltage sag and voltage swell based on UVTG control technique as given below:

The developed model of three-phase DVR system and the proposed control scheme in the MATLAB/ SIMULINK environment is shown in Fig-4 and Fig-5.

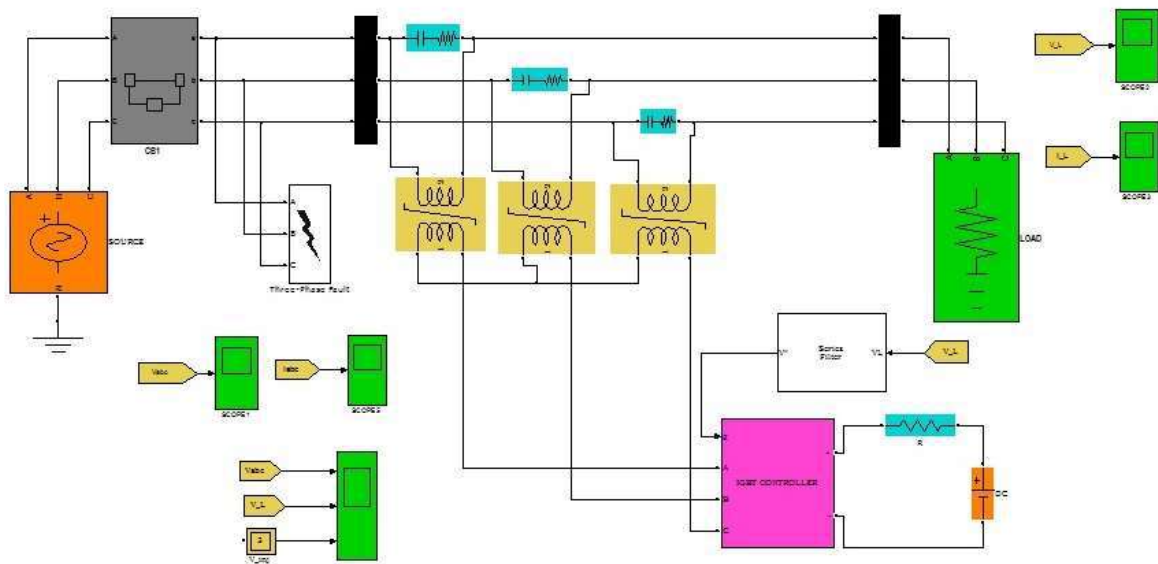

Fig -4 MATLAB Model of DVR

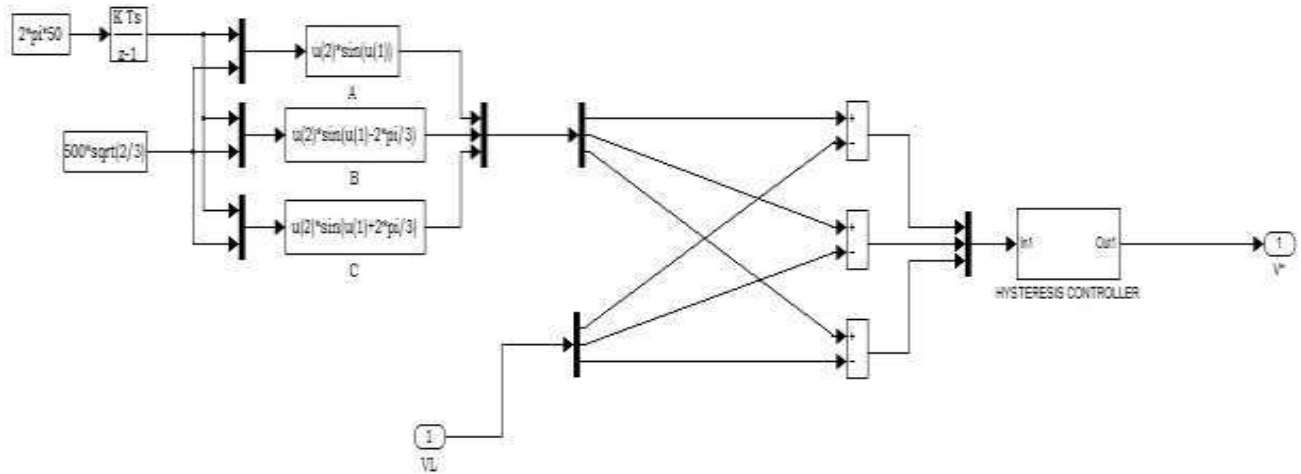

Fig -5 MATLAB Model of DVR Controller

The performance of DVR is evaluated in terms of Sag and Swell, Unbalanced load condition. The performance of the proposed control scheme of three-phase DVR is evaluated for sinusoidal supply voltages as well as distorted supply mains.

Voltage sags/swells caused by some unexpected faults like L-L, L-G, L-L-G, & 3-Phase faults will be having impact on some critical loads. For this problem the DVR injects the voltages to regain and maintain its desired value. DVR injection of voltage with minimized power loss for compensation point of view can be reached by selecting a proper magnitude and phase angle [10]. Fig-6 indicates the performance of the system when 0.8 p.u of voltage sag is introduced in the system at (0.5- 0.7) sec. And the total Sag duration is 0.2 sec. It is seen that the DVR is injected the voltage only when the event of sag occurs and load voltage is restored at 1 p.u. The figure shows the source voltage V_s , DVR injection voltage V_{dvr} , and the load voltage V_{load} respectively.

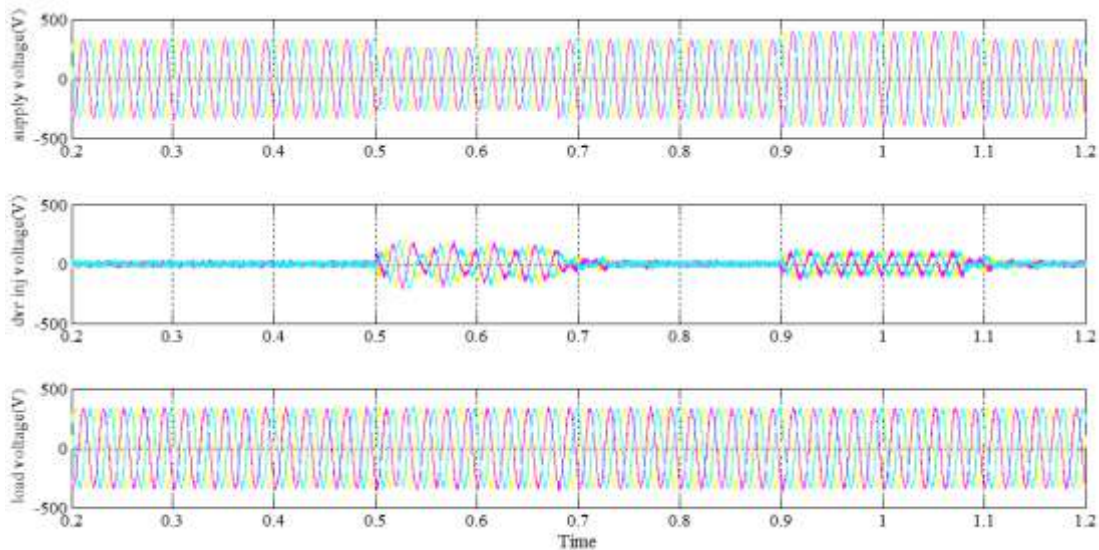

Fig -6 Simulation results of DVR under voltage sag (0.5-0.7) sec and swell (0.9-1.1) sec

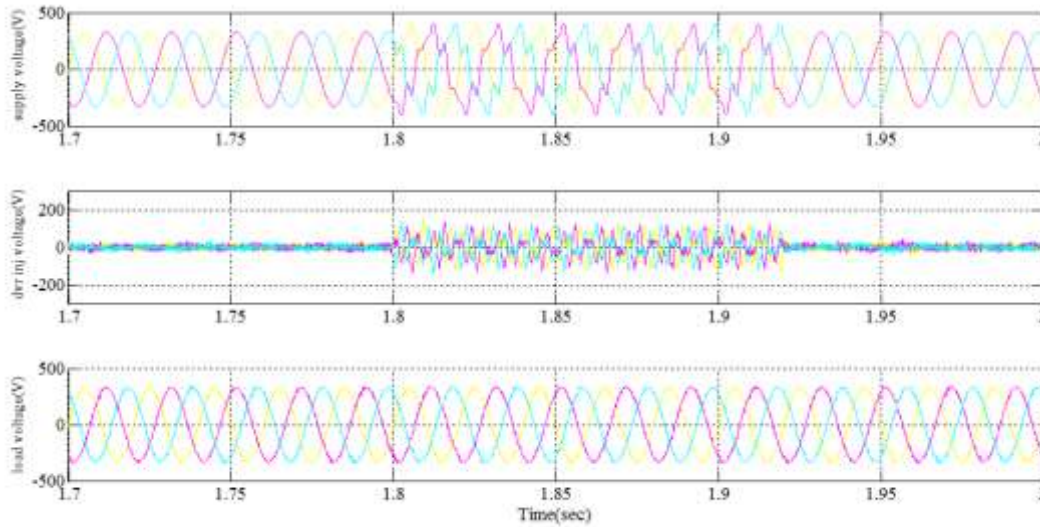

Fig -7 Simulation results of DVR under unbalanced voltage supply

Similarly, Fig-6 is also showing the performance of DVR when 1.2 p.u. swell is introduced in the system at (0.9-1.1) sec. and the total swell duration is 0.2 sec. it is seen that the DVR injects the voltage in the of swell also such that it will be restored to 1p.u. The figure shows that source voltage V_s , DVR injected voltage V_{dvr} , and the load voltage V_{load} respectively. Fig-7 is showing the performance of DVR under distorted voltage condition and for the same distorted voltage.

4. CONCLUSION

This paper propose scheme for power quality improvement based on unit vector template for DVR. In order to show the performance. The modelling and simulation of a DVR using MATLAB/SIMULINK has been presented. In this paper the compensation of voltage sag/swell and compensation for distortion in voltage is analyzed. Whenever the disturbance (sag, swell and distortion) occurs the DVR is supporting by injecting or absorbing voltage, otherwise DVR will be in standby mode.

5. REFERENCES

- [1]. H. Shrivastava Amit Kumar Yadav, A. Mishra, 'Performance Analysis of Dynamic Voltage Restorer (DVR) under Unsymmetrical Fault condition', IJRST, Vol 4, Issue 9, Feb 2018
- [2]. A. Ghosh and G. Ledwich, Power Quality Enhancement Using Custom Power Devices., U.K.: Kluwer, 2002.
- [3] R. C. Dugan, M. F. McGranaghan, and H. W. Beaty, Electric Power Systems Quality, 2nd ed. New York, NY, USA: McGraw-Hill, 2006.
- [4] A. Moreno-Munoz, Power Quality: Mitigation Technologies in a Distributed Environment. London, U.K.: Springer-Verlag, 2007.
- [5] K. R. Padiyar, FACTS Controllers in Transmission and Distribution .New Delhi, India: New Age Int., 2007.

- [6] IEEE Recommended Practices and Recommendations for Harmonics Control in Electric Power Systems, IEEE Std. 519, 1992.
- [7] V. B. Bhavraju and P. N. Enjeti, "An active line conditioner to balance voltages in a three phase system," IEEE Trans. Ind. Appl., vol. 32, no. 2, pp. 287–292, Mar./Apr. 1996.
- [9] M. Vilathgamuwa, R. Perera, S. Choi, and K. Tseng, "Control of energy optimized dynamic voltage restorer," in Proc. IEEE IECON, 1999, vol. 2, pp. 873–878.
- [10] M. Karimian and A. Jalilian, "Proportional-repetitive control of a dynamic voltage restorer (DVR) for power quality improvement," in Electrical Power Distribution Networks (EPDC), 2012, Proceedings of 17th Conference on, 2012, pp. 1-6.
- [11]. M. Hembram and A. K. Tudu, "Mitigation of power quality problems using unified power quality conditioner (UPQC)," C3IT, Hooghly, 2015, pp. 1-5.
- [12]. F. A. Jowder, "Modeling and Simulation of Dynamic Voltage Restorer (DVR) Based on Hysteresis Voltage Control," The 33rd Annual Conference of the IEEE Industrial Electronics Society (IECON) Nov. 2007, pp. 1726-1731